



# **CASTLEBERRY Instruments & Avionics**

## **MODEL 300-14EL SELECTION AND INSTALLATION GUIDE**

### **APPLICABILITY**

Before installing the 300-14EL gyro part number 504-0006-954 through 504-0006-957, determine that it is appropriate for the application. This gyro comes either as a 14 Volt or a 28 Volt model. Select the part number that is right for the voltage of the aircraft. Also this gyro is designed for use in fixed wing aircraft with shock mounted panels. It is not intended for use in acrobatic flying. This gyro can travel unrestricted 360 degrees through the roll axis but is limited to  $\pm 90$  degrees of pitch travel.

This product conforms to FAA technical specifications TSO C4c. It is responsibility of the installer and their authority to determine proper use, purpose, and documentation required to install this product. We do recommend that installers become familiar with FAA advisory circular AC91-75 and special airworthiness information bulletins CE-05-15 and CE-05-41 since these documents relates to purpose for recent applications of installing this product.

There are no life limited parts or periodic scheduled maintenance requirements on this product to generate a need for continued airworthiness procedures.

### **OPTIONS**

Panel tilt is an important specification required to be known when ordering or installing a panel mounted attitude gyro in an aircraft. If panel tilt is not known, the manufacturer of the aircraft should be able to provide that information. This gyro can be calibrated for a panel tilt from zero to fourteen degrees and should be specified when ordering. A label is attached to the gyro to indicate the tilt calibration of each unit. If a newly installed attitude gyro settles more than  $\pm 1\frac{1}{2}$  degrees pitch above or below where the expected horizon should be, then panel tilt or aircraft trimming issues should be suspected. Note that the -955 or -957 (depending upon voltage type) should be selected when any tilt other than zero degrees is desired.

### **LIGHTING**

The 300-14EL is integrally lighted with externally selectable light tray. The unit comes with a light tray of the same operating voltage as the gyro, however it may be replaced with other voltage types. Castleberry Instruments has 5, 14 and 28 Volt types available. The wiring to lights is via flying leads that can be easily connected by installer's choice of connectors to the lighting buss. Lamps are of incandescent type and may be operated by either AC or DC Voltages. The polarity does not matter.

### **ELECTRICAL**

This model uses approximately 28 Watts starting and 17 Watts running. Therefore current rating for the 14 Volt model is 2 Amps maximum and the 28 Volt model 1 Amp maximum. Power to gyro is applied through a common 4 pin circular connector on rear of unit as shown on the drawings of following pages. Supplied with a new unit is mating connector Castleberry P/N 8821-1032-0001 or cable 8824-1024-090(x) (either a -0901 for a 14V unit or -0902 for a 28V unit). The industrial part number for the mating connector is MS3116F8-4S or PT06E8-4S(SR). Recommended wire size is 22 to 20 AWG and should be of aircraft approved type. Circuit breaker or protection devices must be large enough to support the maximum current for voltage type but small enough to protect aircraft wiring. Note that pin out is different for the two different voltage models to prevent accidentally applying wrong voltage. Ground or Negative is always to pin "A" and +14 Volts to pin "B" for the 14 Volt models and +28 Volts to pin "C" for the 28 Volt models.

**WARNING:** Applying power to gyro reverse polarity or allowing a voltage spike exceeding 39 VDC will blow an internal fuse to protect the gyro circuitry. If fuse becomes blown, unit must be repaired and tested before returning to service.

### **MECHANICAL**

Panel cut out and mounting hole information are on following pages. This gyro is designed to be installed rear mounted on a shock mounted panel. Be sure that installation screw length penetrates into gyro bezel approximately 1 inch after considering panel thickness including any shim or wedge application. Read all notes on following outline drawings to be aware of any limitations or specifications that may apply to your installation requirements.



0041-1025

NOTICE: This document contains PROPRIETARY designs, specifications, information & technical material that is the SOLE PROPERTY of CASTLEBERRY Instruments & Appliances, L.L.C. to be held & treated by its recipient on a CONFIDENTIAL basis, not to be shown or disclosed to any unauthorized person or organization.

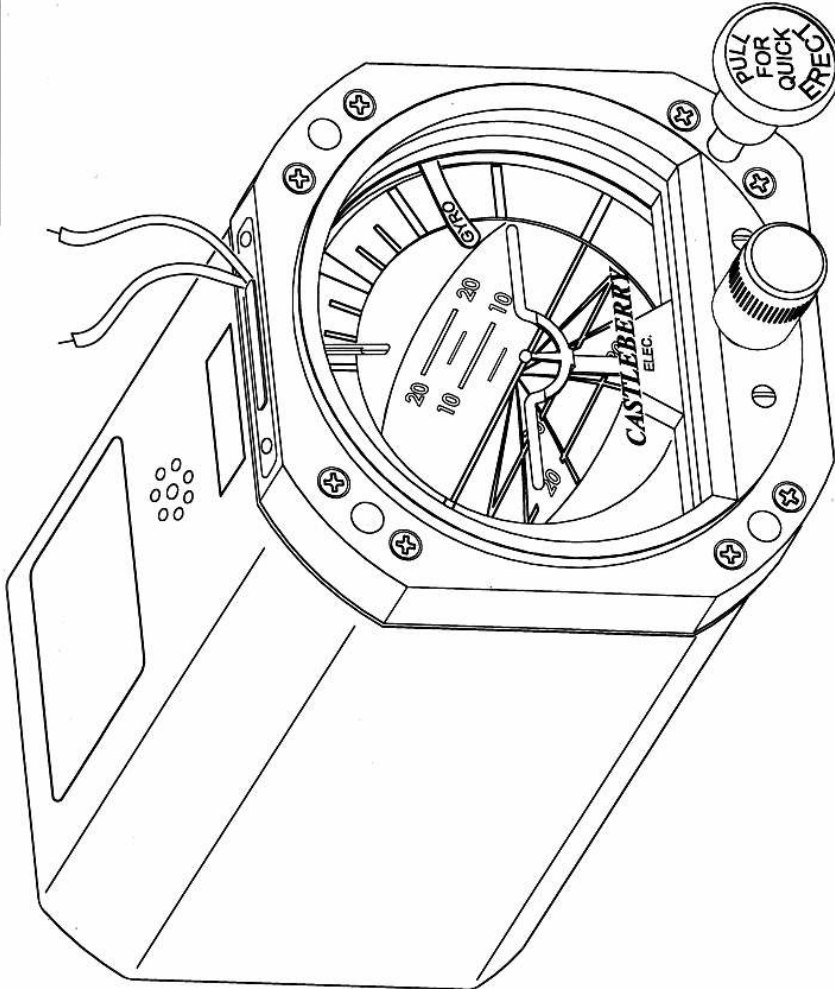

Model 300-14EL 'Mod. A'  
with new bezel (shown  
without inclinometer).

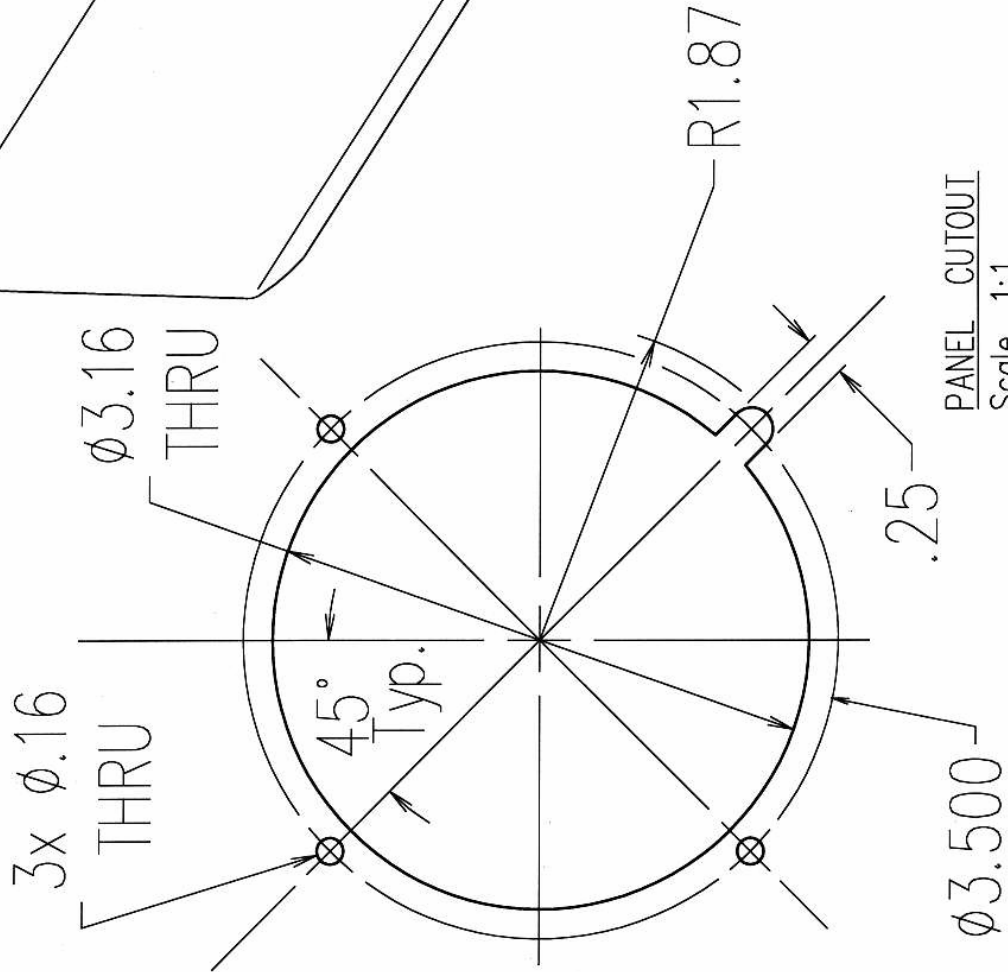

PANEL CUTOUT  
Scale 1:1

DATE		REV.	BY	CHKD.	DATE	APP.	SCALE	TYPE
1/23/07	C2378	N					1:1	
8/1/08	C2320	M						
7/21/08	C2314	L						
5/6/08	C2296	K						
2/17/06	C2161	J						
DATE		REV.	BY	CHKD.	DATE	APP.	SCALE	TYPE
					Feb. 20, 2002	jit	1:1	N

CASTLEBERRY INSTRUMENTS & APPLIANCES		Austin, Texas	
UNLESS OTHERWISE SPECIFIED: DIMENSIONS ARE IN INCHES FRACTIONS SHALL BE IN 16ths DECIMALS SHALL BE TO 2 PLACES TOLERANCES UNLESS OTHERWISE SPECIFIED: FRACTIONS ± 1/16" DECIMALS ± .005" 3 PLACE DECIMALS ± .001" 4 PLACE DECIMALS ± .0005"			
OUTLINE DRAWING, 300-14EL		MATERIAL	
		FINISH	
		SCALE (APPROX.)	
		TYPE	